

# Pendant Loudspeaker

IPS60



## Description:

The IPS60 is a pendant speaker built-in 70v/100v transformer. The 70v/100v transformer technique reduces line losses on longer distance and allows easy parallel connection of multiple loudspeakers. The built-in 6" full range speaker driver is designed of wide frequency response 130 -15kHz, the multiple power taps of 5W/10W/20W could meet different applications varies from room size and ambient noise surroundings. The ABS enclosure is of white color. Easy and secure wall mount installation through the supplied secured steel mounting ring kit. It is ideal choice for industrial and commercial applications in the outdoor area of train station, shopping mall, parking area and factory where background music and paging is needed.

## Features:

- Built-in 100v/70v transformer.
- Pendant type loudspeaker for high roof applications.
- Suitable for hotel lobby or cash desk use.
- 360-degree sound wide dispersion angle.
- 6" full range speaker driver.
- Power taps at 5w-10w-20w @100V.
- ABS enclosure of White color.
- With security ring lock to prevent from drop.

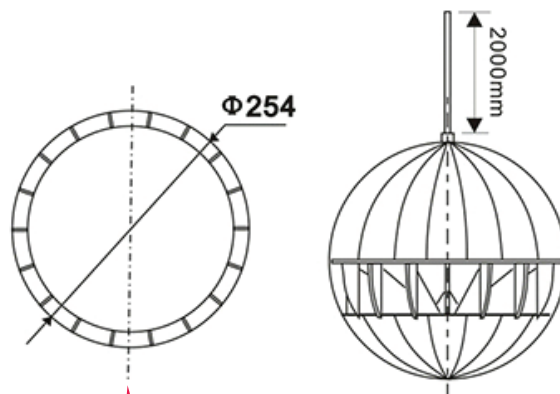

# Pendant Loudspeaker

## Specification:

<b>Model</b>	<b>IPS60</b>
Frequency Response	130-15KHZ
Sensitivity	92 3dB
Power Handling	20W
Power tap	5W /10W /20W
Line input	100V
mounting	pendant hung
Dimension(diameter)	Φ254
Material	ABS(white ral 9016)
Componen	8"
Finished Colour	white ral 9016
Net weight	2.2KG
Gross weight	3.1kg/1pc
Packing Dimension	330330310
Finished Color	White
Voice Coil Size	KSV 2040142 T
DC Impedance	7.2Q
Former	KAPTON
Magnet	Ferrite(305 g) Φ80*32*15 (Y30)
Basket	Iron
Cone Materia	Paper
Spider	Cloth
Dust cap	Paper Cup
Net Weight	640g